

THIS DRAWING IS UNPUBLISHED. RELEASED FOR PUBLICATION
 © COPYRIGHT BY TYCO ELECTRONICS CORPORATION. ALL RIGHTS RESERVED.

LOC	DIST	REVISIONS			
P	LTR	DESCRIPTION	DATE	DWN	APVD
BD	0	0	RELEASED PER EC 0S13-0207-05	30JUN05	SW JG

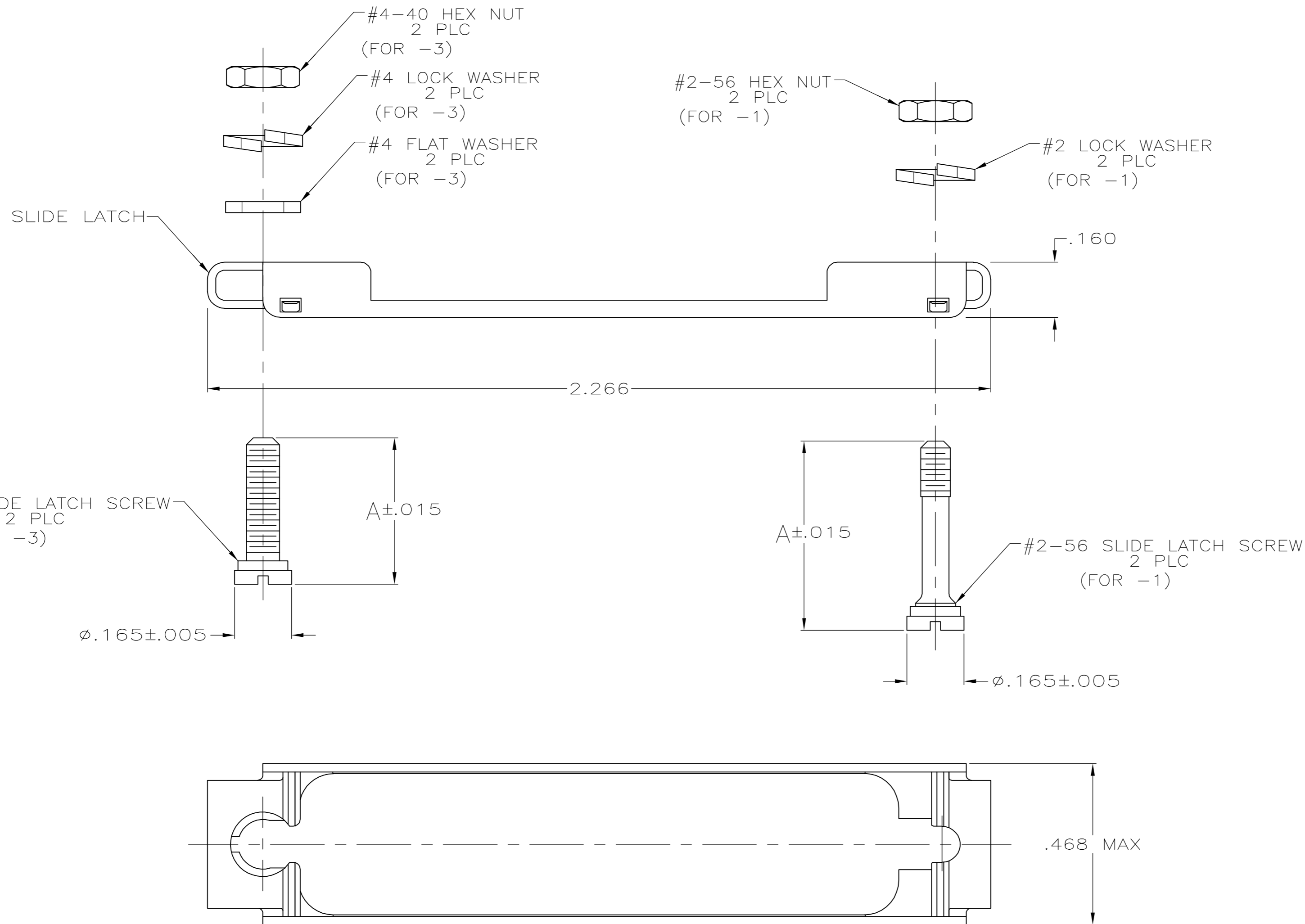

- PARTS PACKAGED UNASSEMBLED.
- PARTS PACKAGED AS A UNIT KIT.
- ZINC PLATED .000200-.000400 THICK, CLEAR CHROMATE COATING.
- ZINC PLATED .000200-.000400 THICK, YELLOW CHROMATE COATING.
- THIS KIT CAN BE USED WITH TWO-PIECE STRAIGHT/90° EXIT CABLE CLAMPS, RFI/EMI CABLE CLAMPS OR UNIVERSAL CABLE CLAMPS.
- THIS KIT CAN BE USED WITH STRAIGHT/45° EXIT ONE-PIECE CABLE CLAMPS, STRAIGHT/90° EXIT ONE-PIECE CABLE CLAMPS, OR ON CONNECTORS WITHOUT CABLE CLAMPS.

.415	4	#4-40	6	5745584-3
.547	3	#2-56	5	5745584-1
A	HARDWARE FINISH	THREAD TYPE	PART NO	

THIS DRAWING IS A CONTROLLED DOCUMENT.		DWN	30JUN05	Tyco Electronics Corporation	
DIMENSIONS: INCHES		S.WAITMAN	30JUN05	Harrisburg, Pa 17105-3608	
TOLERANCES UNLESS OTHERWISE SPECIFIED:		CHK	30JUN05	NAME	
0 PLC ± -		J.GERACE	30JUN05	KIT, SLIDE LATCH, SIZE 3, 25 POSITION, AMPLIMITE	
1 PLC ± -		APVD	30JUN05	PRODUCT SPEC	
2 PLC ± -		M.WALMSLEY	30JUN05	APPLICATION SPEC	
3 PLC ± .010		-		SIZE	
4 PLC ± -		-		CAGE CODE	
ANGLES ± -		-		DRAWING NO	
FINISH		WEIGHT		RESTRICTED TO	
SLIDE LATCH: STAINLESS STEEL		-		-	
HARDWARE: STEEL		HARDWARE: SEE TABLE		SCALE	
-		A2 00779		C=5745584	
CUSTOMER DRAWING		SCALE 4:1		SHEET 1 OF 1	
-		-		REV 0	